













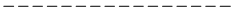



Legende BT:

	Gras
	Kasseien
	Betonstraatstenen 22x22 halfsteensverband
	Betonstraatstenen 22x11 halfsteensverband
	Betonstraatstenen 22x11 visgraatsverband
	Asfalt
	Gebouw
	Muur
	Grasdallen

















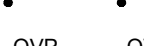

Legende NT:

	Gras
	Natuursteen kasseien
	Zwarte betonstraatstenen 22x22 halfsteensverband
	Beton
	Asfalt
	Kasseien parkeerstrook
	Gebouw
	Muur
	Aarde
	Grasdallen
	Grindgazon
	Kasseien met grasvoeg

Lijnen grondplan:

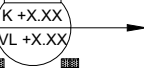
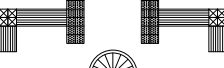
	As rijweg
	Boordsteen
	Grens tussen verhardingen
	Kantstrook
	Wegmarkering
	Grens der werken
	Riolering DWA
	Riolering RWA
	Riolering GWA
	Gevel gebouw
	Gracht
	Afsluiting draad
	Afsluiting haag
	Afsluiting palen
	Dorpel van een gebouw / trappen
	Kelderrooster / Muur
	Fiets-rijrichting

Wegaanhorigheden grondplan:

	inspectieputten riolering
	Bestaande boom
	Afsluiten Water / Gas
	Nieuwe boom
	Straatkolk
	Hydrant ondergronds / bovengronds
	Fietsenstalling
	Antiparkeerpaal - Verkeersbord
	Paal gas - paal hydrant
	Openbare verlichting op paal - gevel
	Parkeermeter
	Gent nietje
	Aanduiding inspectieput riolering DWA
	Aanduiding inspectieput riolering RWA
	Aanduiding inspectieput riolering GWA
	Blindengeleiding
	Vuilnisbak
	Inrit gebouw
	Verkeerskussen



BARRESTRAAT CLUSTER

Ridderstraat Bestaande toestand

Grondplan

INDEX	DATUM	TEKENAAR	OMSCHRIJVING
A	21/10/2021	VANRENTERGHEM A.	Plotten van de plannen

PLANNR.: P_B_01

OPGEMETEN: --- GETEKEND: A. VANRENTERGHEM NAGEZIEN: S. BERNAERDT
DIENST WEGEN, BRUGGEN EN WATERLOPEN - WOODROW WILSONPLEIN 1 - 9000 GENT - TEL: 09 266 79 00

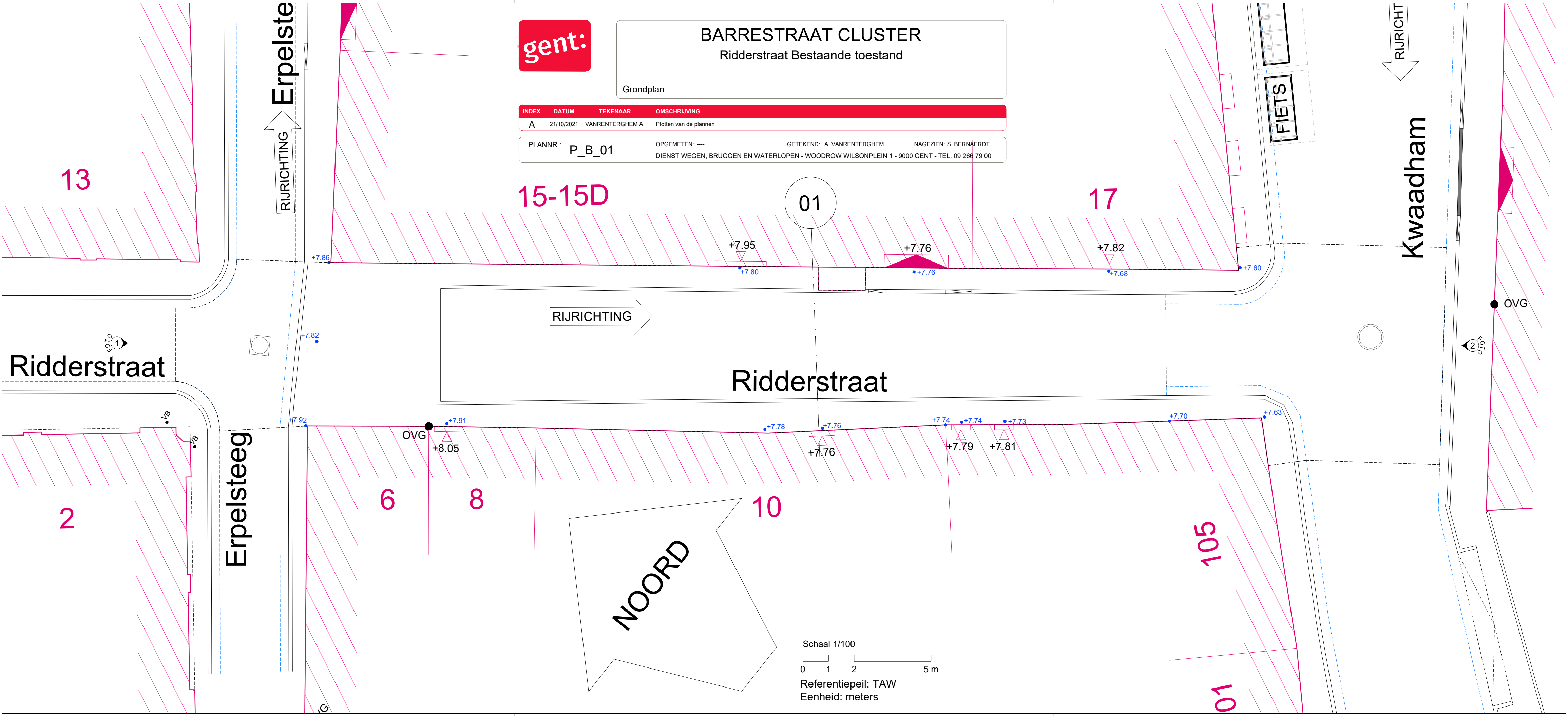

Schaal 1/100
 0 1 2 5 m
 Referentiepeil: TAW
 Eenheid: meters

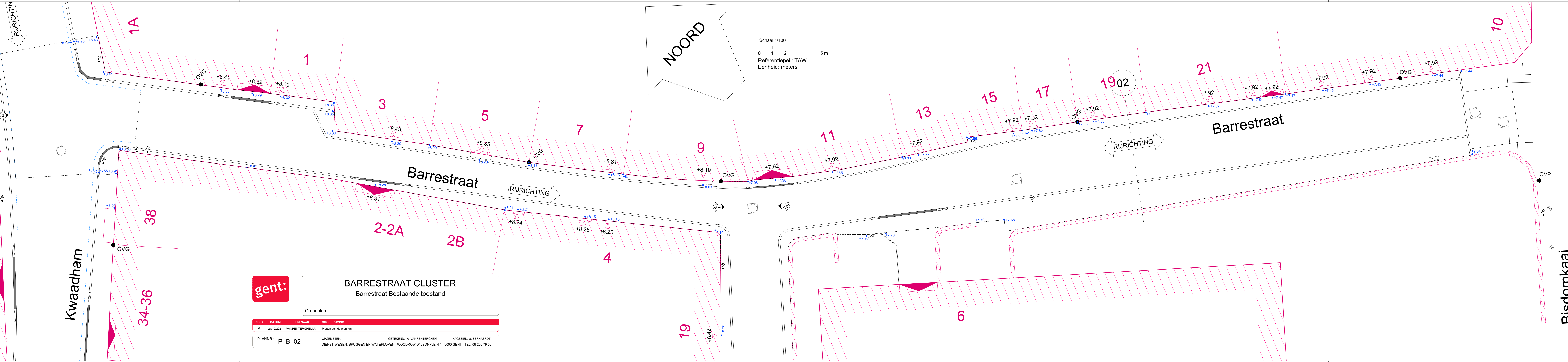

gent:

BARRESTRAAAT CLUSTER
Barrestraat Bestaende toestand

Grondplan

INDEX	DATUM	TEKENAAR	OMSCHRIJVING
A	21/10/2021	VANRENTERGHEM A.	Plotten van de plannen

PLANNR.: P_B_02

OPGEMETEN: ----

GETEKEND: A. VANRENTERGHEM

NAGEZIEN: S. BERNAERDT

DIENTST WEGEN, BRUGGEN EN WATERLOPEN - WOODROW WILSONPLEIN 1 - 9000 GENT - TEL: 09 266 79 00

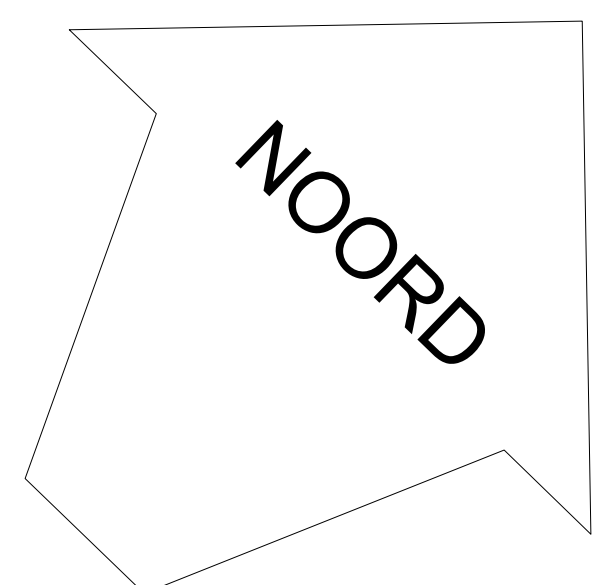
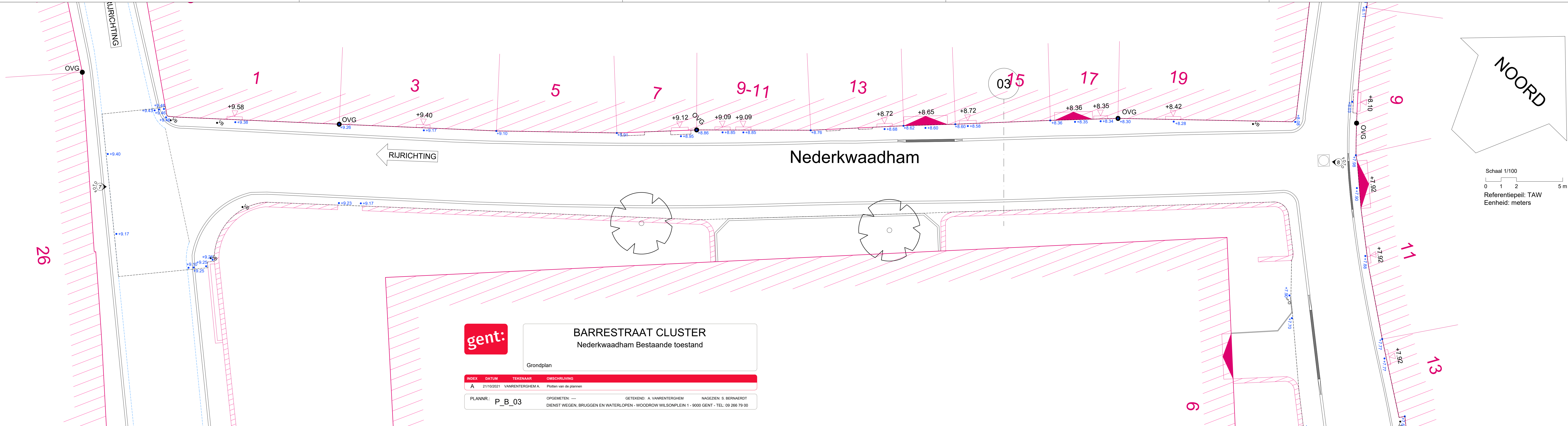

Schaal 1/100
 0 1 2 5 m
 Referentiepeil: TAW
 Eenheid: meters

gent:

BARRESTRAAAT CLUSTER
 Nederkwaadham Bestaande toestand

Grondplan

INDEX	DATUM	TEKENAAR	OMSCHRIJVING
A	21/10/2021	VANRENTERGHEM A.	Plotten van de plannen

PLANNR.: P_B_03

OPGEMETEN: ---

GETEKEND: A. VANRENTERGHEM

NAGEZIEN: S. BERNAERDT

DIENTST WEGEN, BRUGGEN EN WATERLOPEN - WOODROW WILSONPLEIN 1 - 9000 GENT - TEL: 09 266 79 00



BARRESTRAAT CLUSTER

Ridderstraat Bestaande toestand riolering

Grondplan

INDEX	DATUM	TEKENAAR	OMSCHRIJVING
A	21/10/2021	VANRENTERGHEM A.	Plotten van de plannen

PLANNR.: P_B_04	OPGEMETEN: ---	GETEKEND: A. VANRENTERGHEM	NAGEZIEN: S. BERNAERDT
DIENST WEGEN, BRUGGEN EN WATERLOPEN - WOODROW WILSONPLEIN 1 - 9000 GENT - TEL: 09 266 79 00			

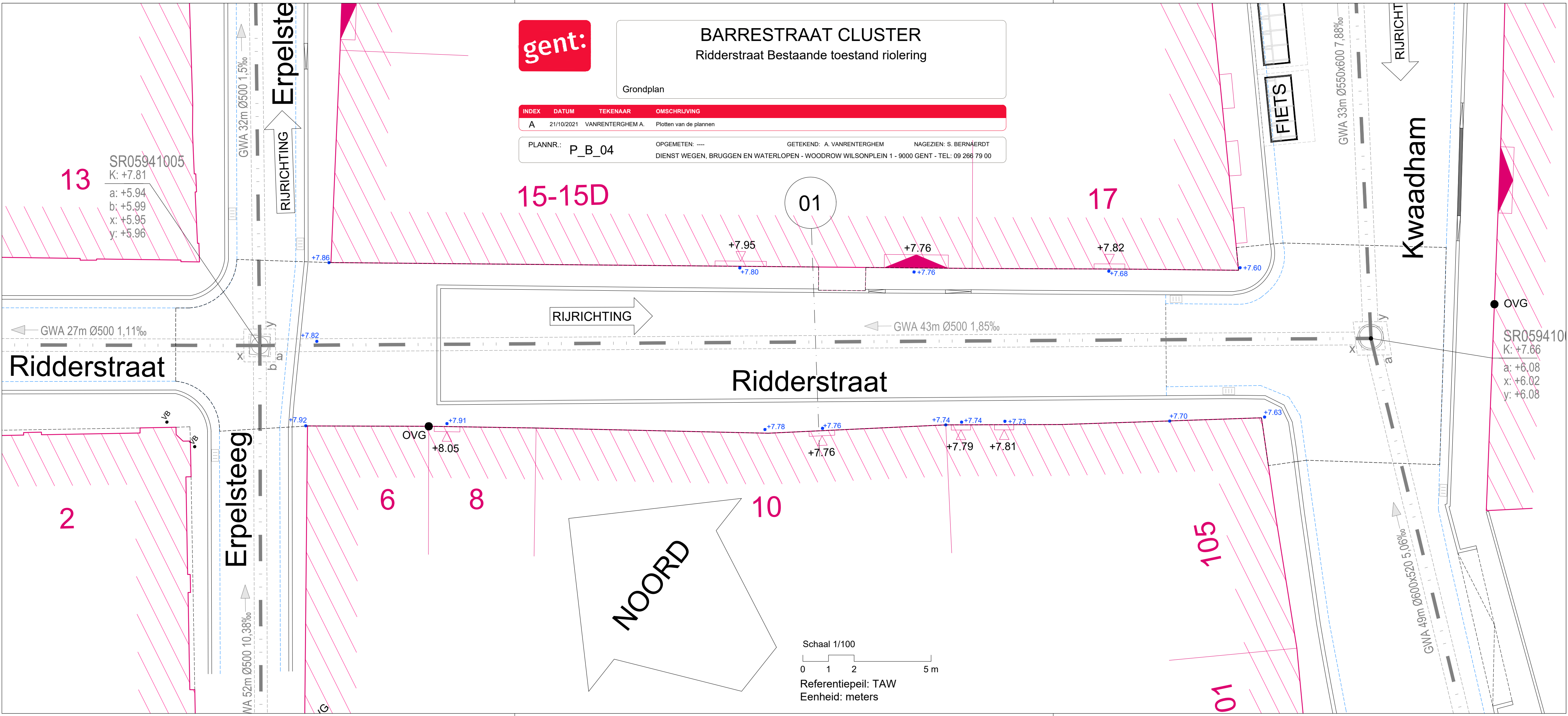

13
SR05941005
K: +7.81
a: +5.94
b: +5.99
x: +5.95
y: +5.96

OVG
SR059410
K: +7.66
a: +6.08
x: +6.02
y: +6.08

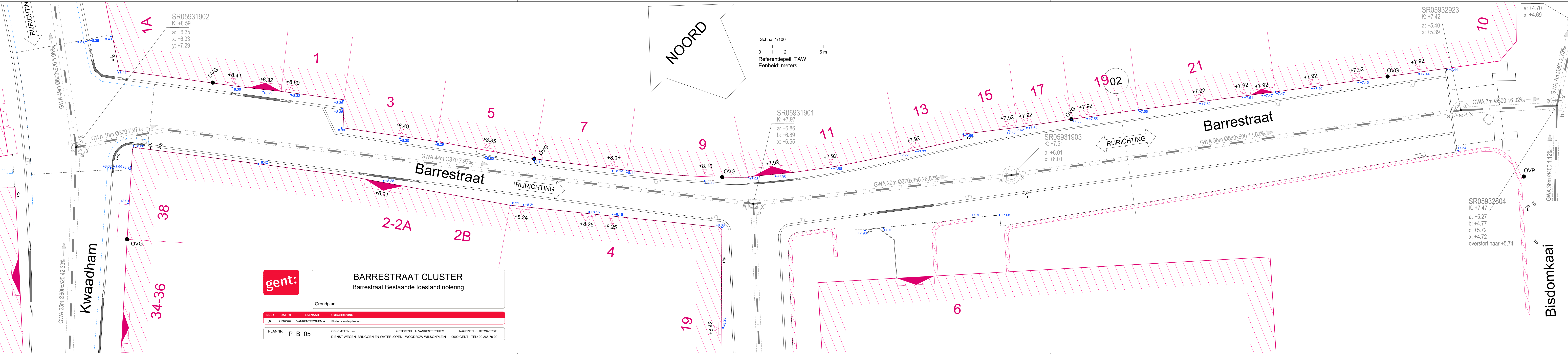

gent:

BARRESTRAAT CLUSTER
Barrestraat Bestaande toestand riolering

Grondplan

INDEX	DATUM	TEKENAAR	OMSCHRIJVING
A	21/10/2021	VANRENTERGHEM A.	Plotten van de plannen

PLANNR.: P_B_05

OPGEMETEN: ----

GETEKEND: A. VANRENTERGHEM

NAGEZIEN: S. BERNAERDT

DIENTST WEGEN, BRUGGEN EN WATERLOPEN - WOODROW WILSONPLEIN 1 - 9000 GENT - TEL: 09 266 79 00

Bisdomkaai

Kwaadham

NOORD

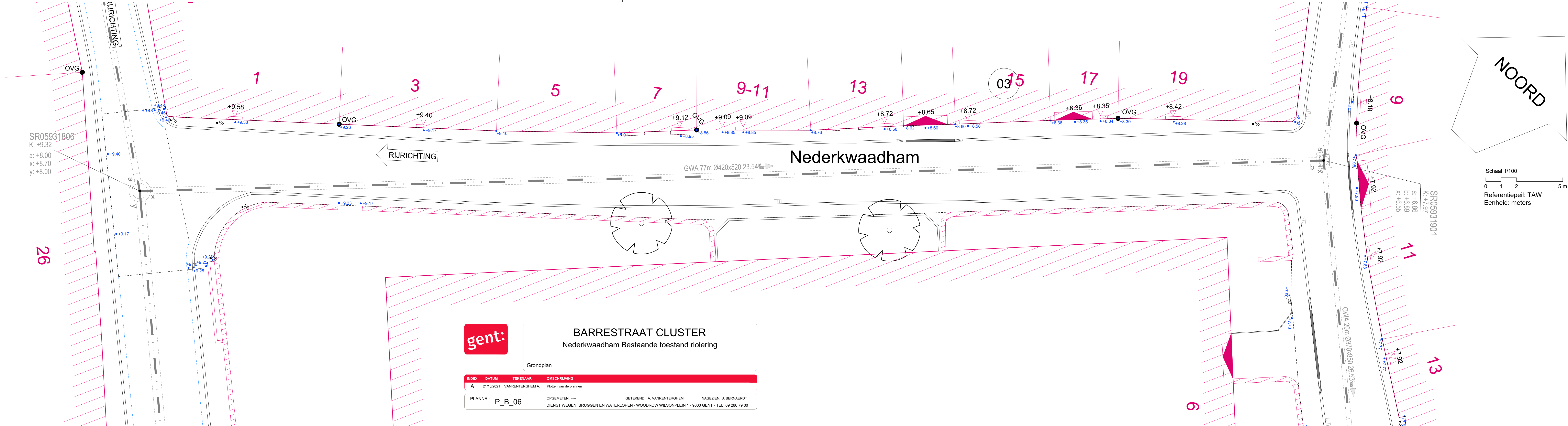

SR05931806
 K: +9.32
 a: +8.00
 x: +8.70
 y: +8.00

SR05931901
 K: +7.97
 a: +6.86
 b: +6.89
 x: +6.55

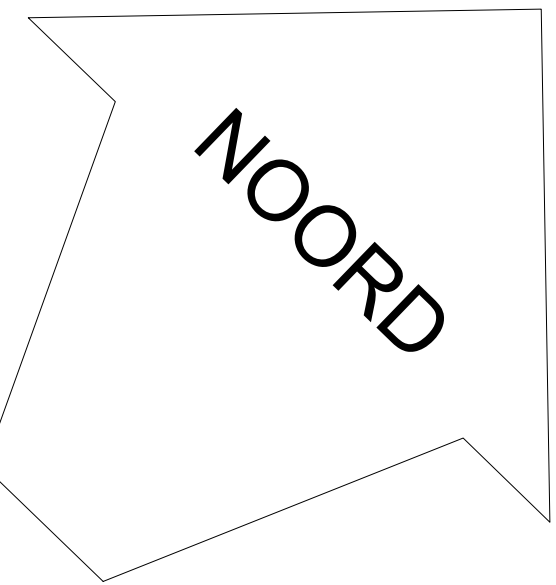

Schaal 1/100
 0 1 2 5 m
 Referentiepeil: TAW
 Eenheid: meters



BARRESTRAAT CLUSTER
 Nederkwaadham Bestaande toestand riolering
 Grondplan

INDEX	DATUM	TEKENAAR	OMSCHRIJVING
A	21/10/2021	VANRENTERGHEM A.	Plotten van de plannen

PLANNR.: P_B_06
 OPGEMETEN: ---
 DIENST WEGEN, BRUGGEN EN WATERLOPEN - WOODROW WILSONPLEIN 1 - 9000 GENT - TEL: 09 266 79 00

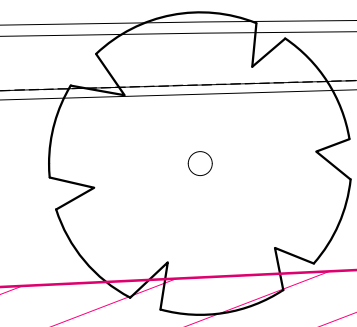
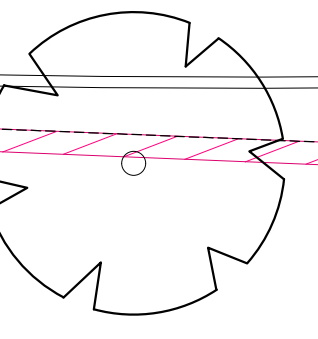

6

11

13

26

1

3

5

7

9-11

13

03 15

17

19

9

NOORD

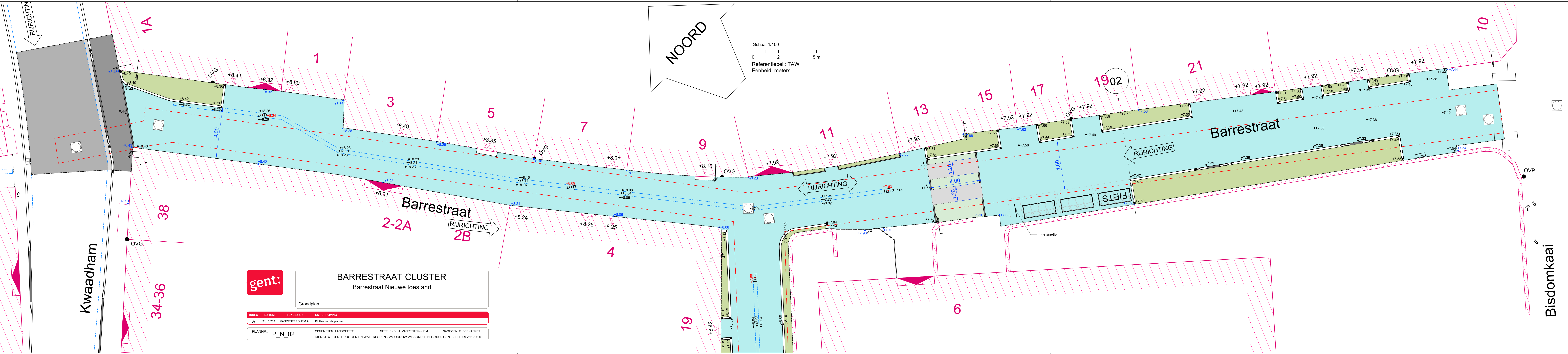

gent:

BARRESTRAT CLUSTER
Barrestraat Nieuwe toestand

Grondplan

INDEX	DATUM	TEKENAAR	OMSCHRIJVING
A	21/10/2021	VANRENTERGHEM A.	Plotten van de plannen

PLANNR.: P_N_02

OPGEMETEN: LANDMETEEL
DIENST WEGEN, BRUGGEN EN WATERLOPEN - WOODROW WILSONPLEIN 1 - 9000 GENT - TEL: 09 266 79 00

GETEKEND: A. VANRENTERGHEM
NAGEZIEN: S. BERNAERT

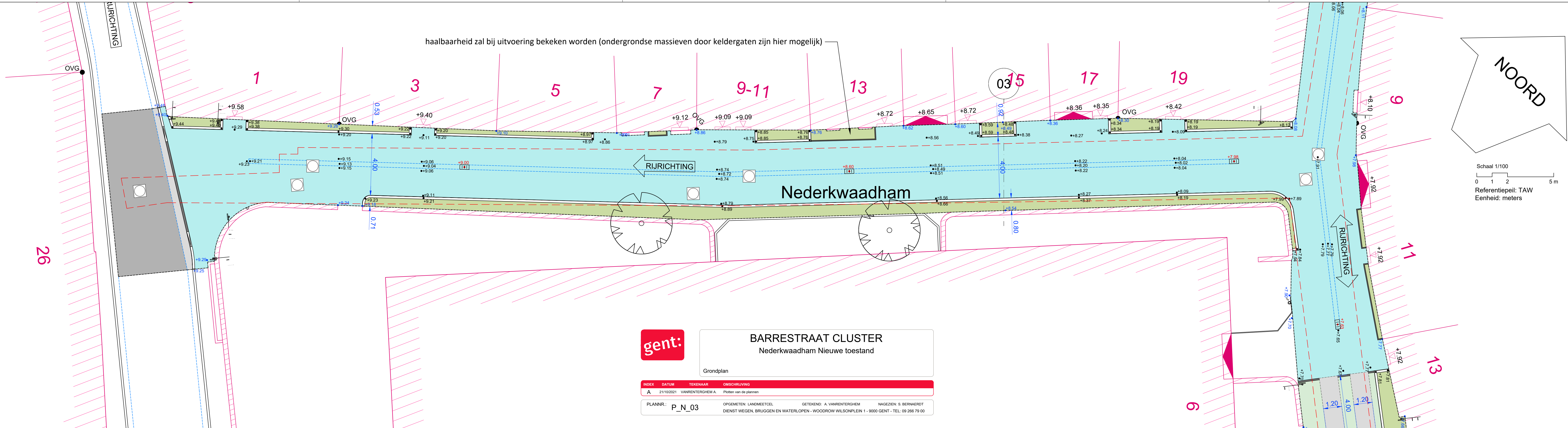

BARRESTRAAAT CLUSTER
Nederkwaadham Nieuwe toestand

Grondplan

INDEX	DATUM	TEKENAAR	OMSCHRIJVING
A	21/10/2021	VANRENTERGHEM A.	Plotten van de plannen

PLANNR.: P_N_03	OPGEMETEN: LANDMEETCEL	GETEKEND: A. VANRENTERGHEM	NAGEZIEN: S. BERNAERT
	DIENST WEGEN, BRUGGEN EN WATERLOPEN - WOODROW WILSONPLEIN 1 - 9000 GENT - TEL: 09 266 79 00		



BARRESTRAT CLUSTER

Ridderstraat Nieuwe toestand riolering

Grondplan

INDEX	DATUM	TEKENAAR	OMSCHRIJVING
A	21/10/2021	VANRENTERGHEM A.	Plotten van de plannen

PLANNR.: P_N_04

OPGEMETEN: LANDMEETCEL
DIENST WEGEN, BRUGGEN EN WATERLOPEN - WOODROW WILSONPLEIN 1 - 9000 GENT - TEL: 09 266 79 00

GETEKEND: A. VANRENTERGHEM
NAGEZIEN: S. BERNAERDT

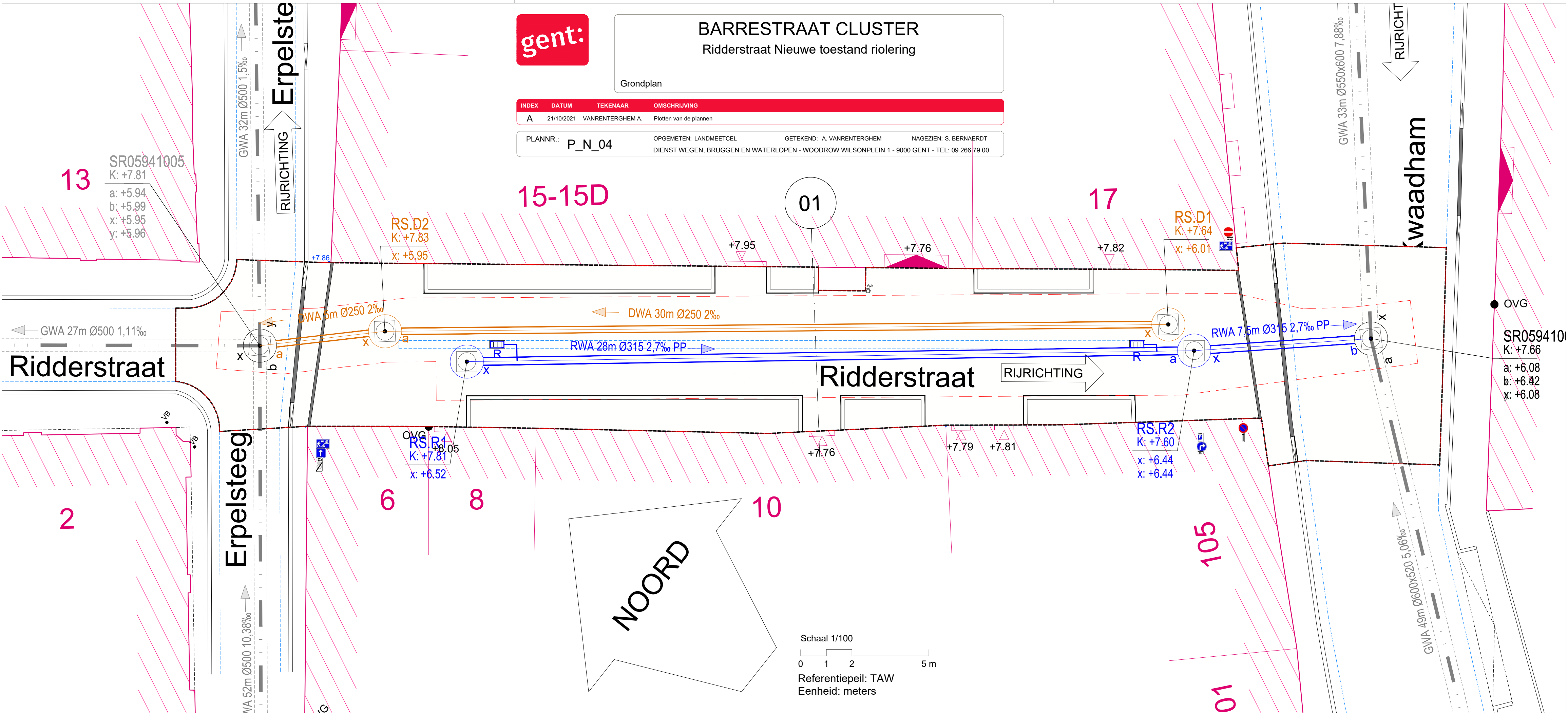

PDF by Vanrenterghem Angelo on 21.10.2021 11:11; Papersize (HxB): 297mm x 630mm

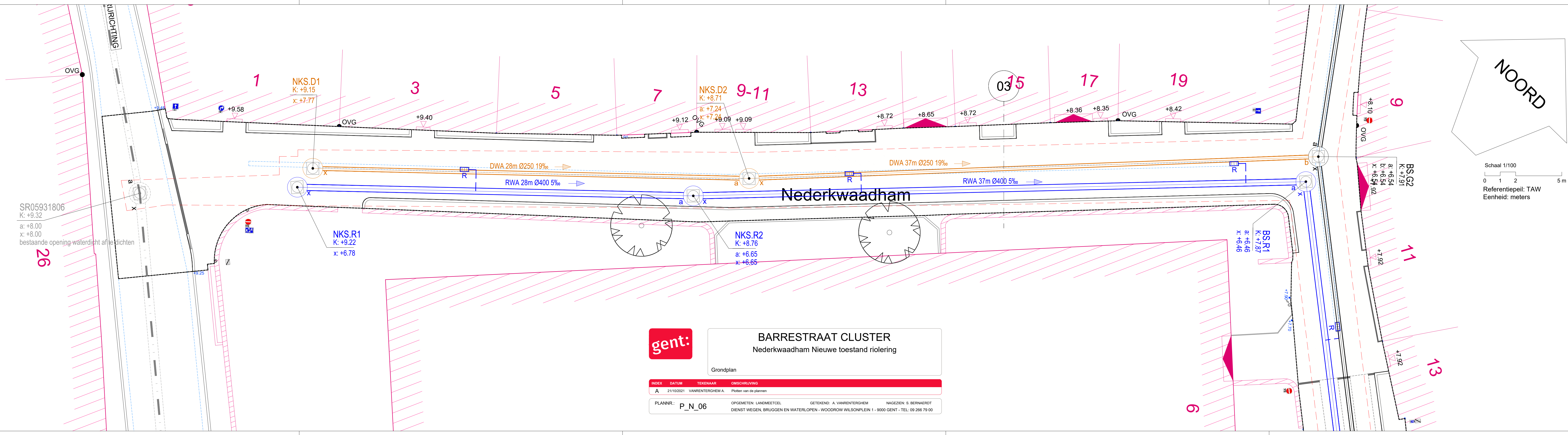

SR05931806
K: +9.32
a: +8.00
x: +8.00
bestaande opening waterdicht afledichten

NKS.D1
K: +9.15
x: +7.77

NKS.D2
K: +8.71
a: +7.24
x: +7.24

NKS.R1
K: +9.22
x: +6.78

NKS.R2
K: +8.76
a: +6.65
x: +6.65

BS.R1
K: +7.87
a: +6.46
x: +6.46

BS.G2
K: +7.91
a: +6.54
b: +6.54
x: +6.54



BARRESTRAAT CLUSTER
Nederkwaadham Nieuwe toestand riolering

Grondplan

INDEX	DATUM	TEKENAAR	OMSCHRIJVING
A	21/10/2021	VANRENTERGHEM A.	Plotten van de plannen

PLANNR.: P_N_06

OPGEMETEN: LANDMEETCEL
DIENST WEGEN, BRUGGEN EN WATERLOPEN - WOODROW WILSONPLEIN 1 - 9000 GENT - TEL: 09 266 79 00

GETEKEND: A. VANRENTERGHEM
NAGEZIEN: S. BERNAERT

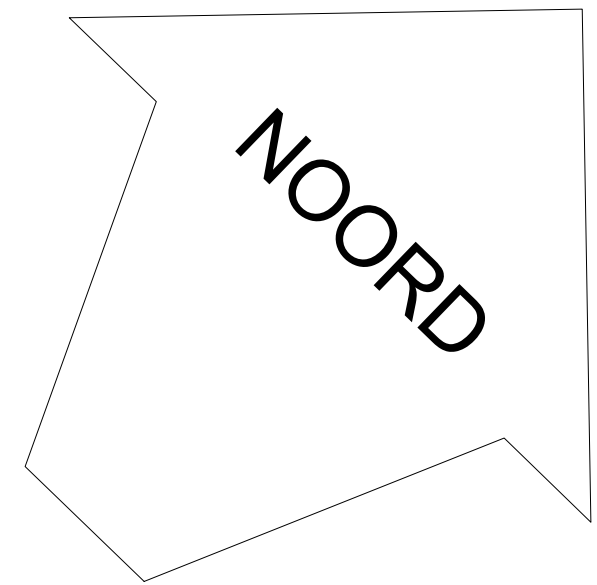

Schaal 1/100
0 1 2 5 m
Referentiepeil: TAW
Eenheid: meters



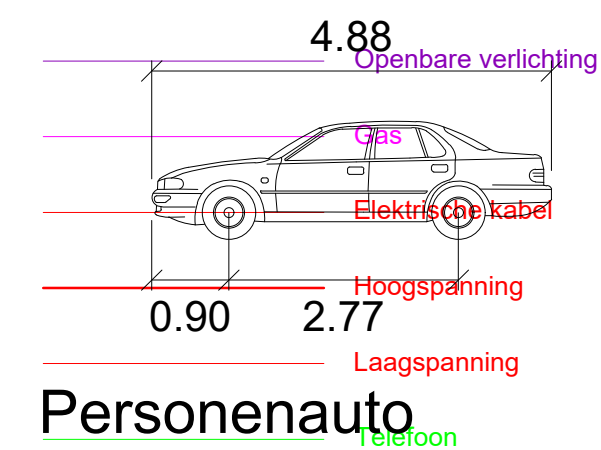

Personenauto
 Width : 1.83 meters
 Track : 1.74
 Lock to Lock Time : 6.0
 Steering Angle : 33.3

Nieuwe toestand in rijrichting voorwaarts binnenrijden

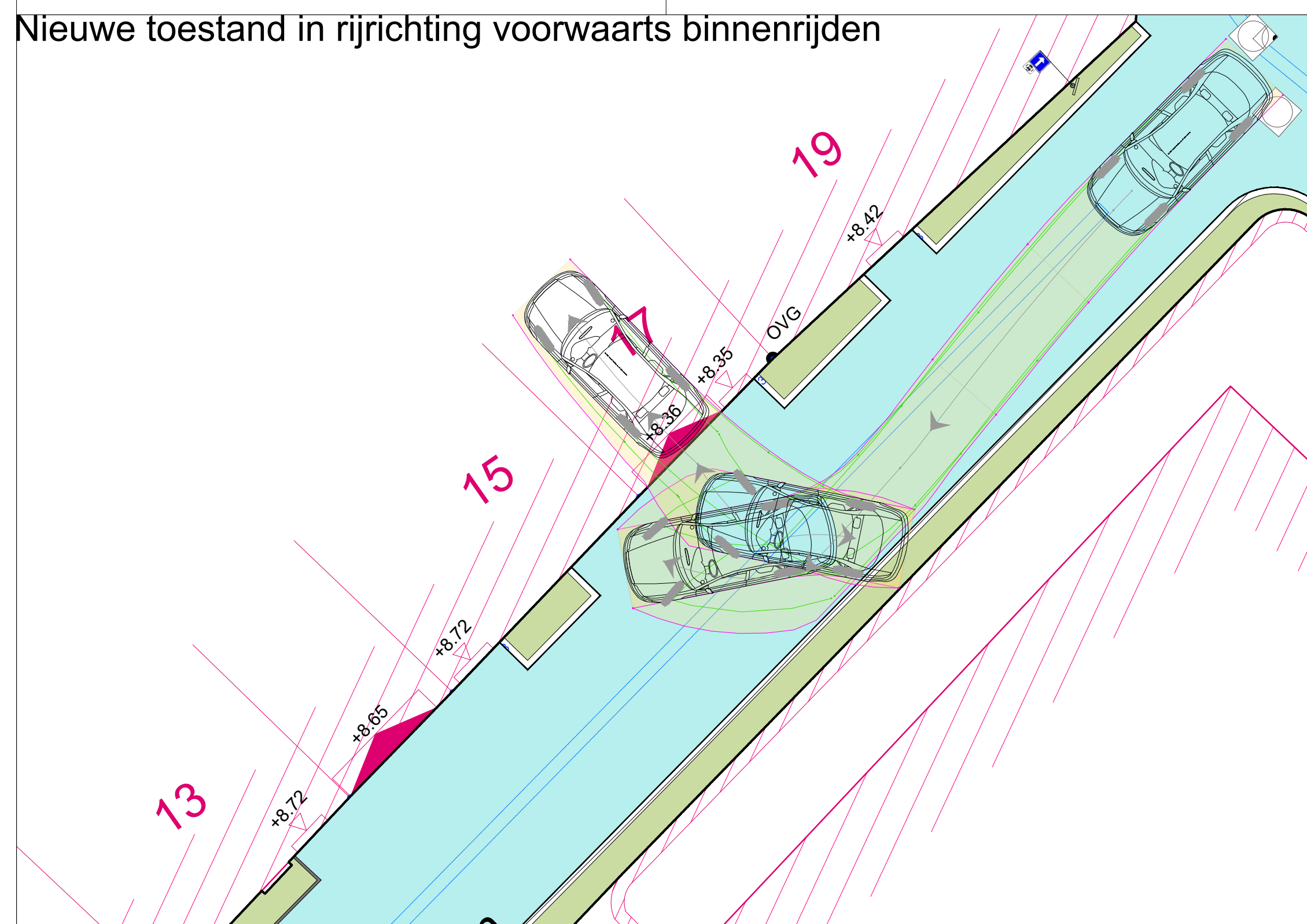

Nieuwe toestand in rijrichting achterwaarts binnenrijden

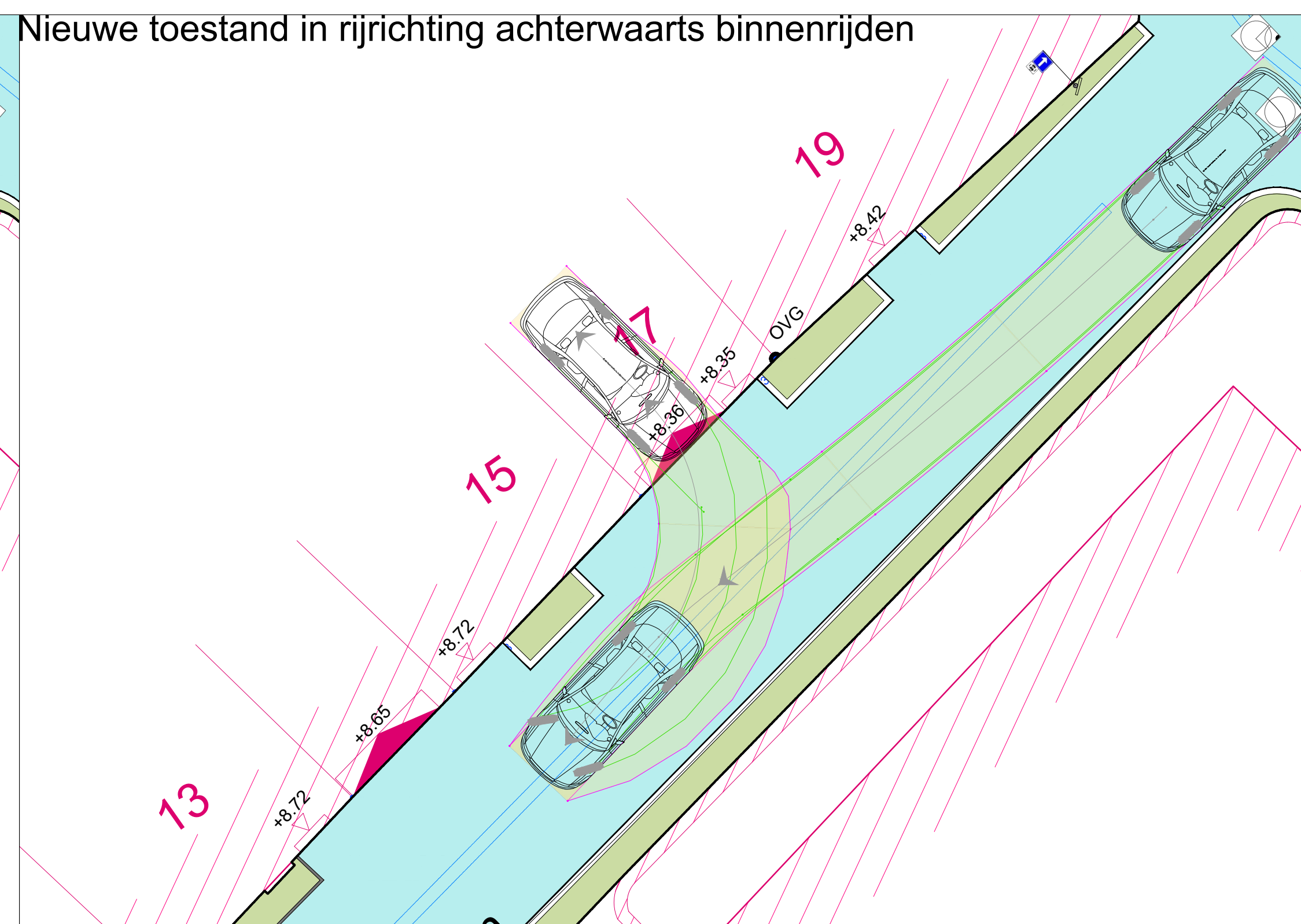

Nieuwe toestand in tegenrichting voorwaarts binnenrijden

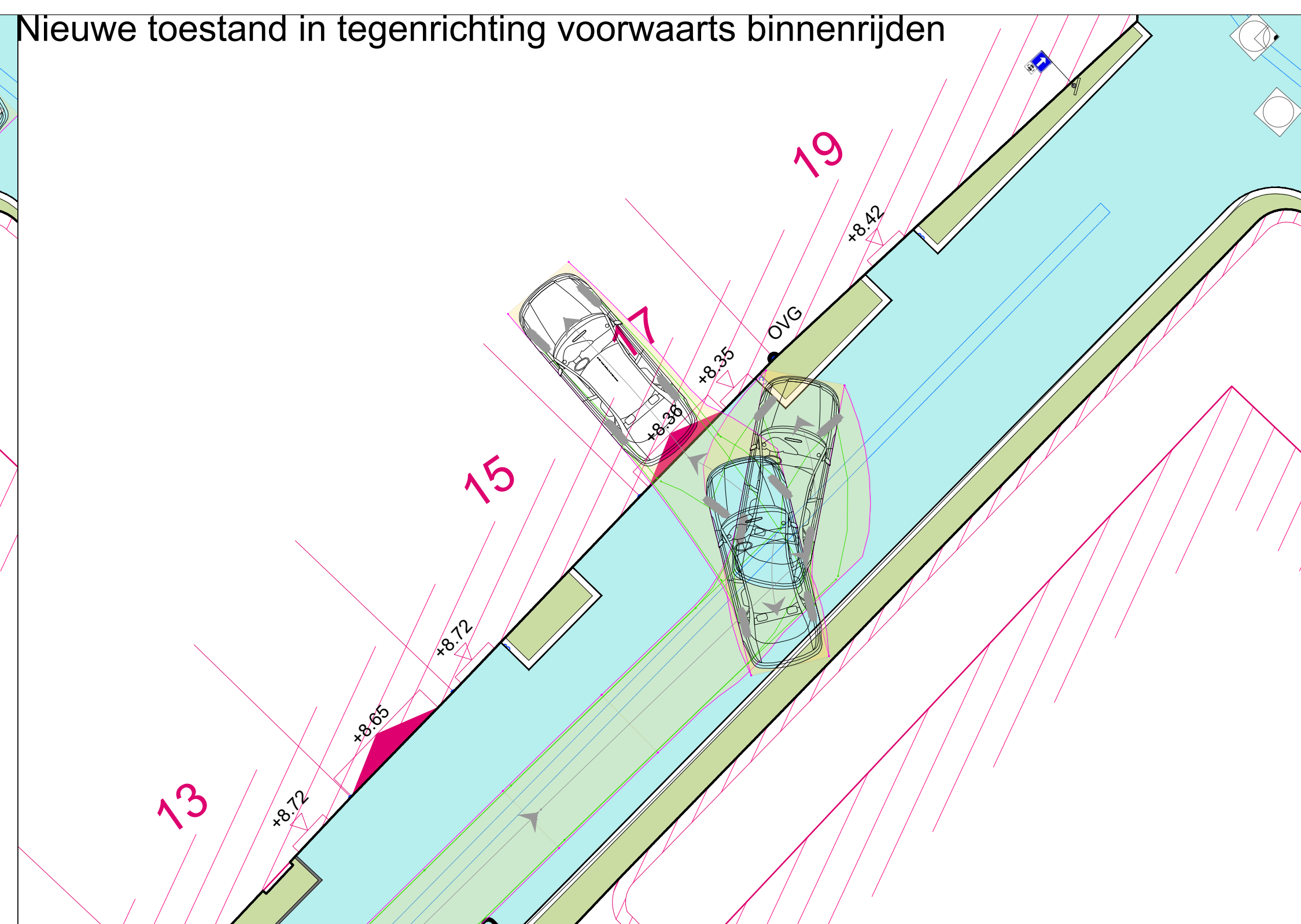

Nieuwe toestand in tegenrichting achterwaarts binnenrijden

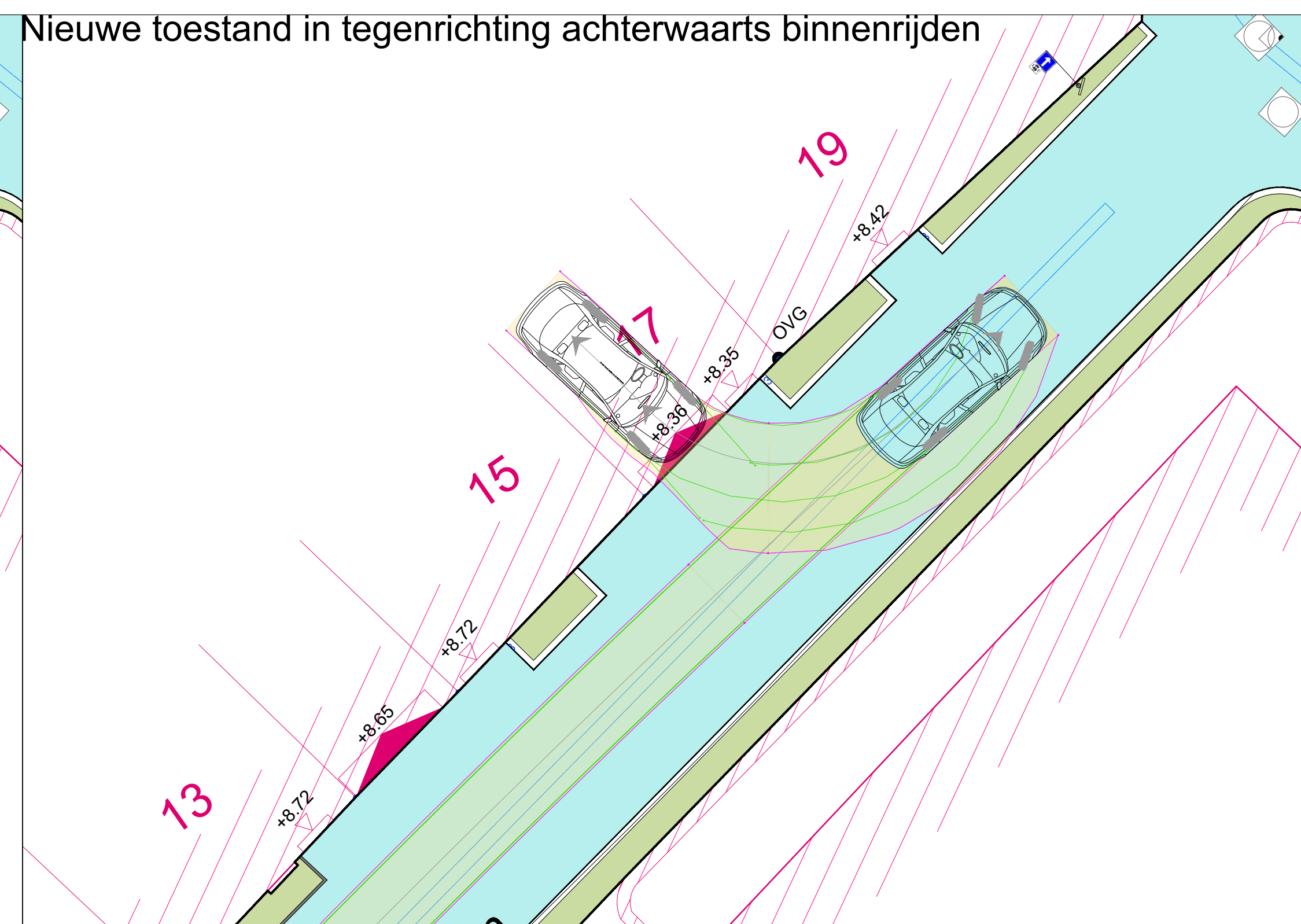

Bestaande toestand in rijrichting voorwaarts binnenrijden

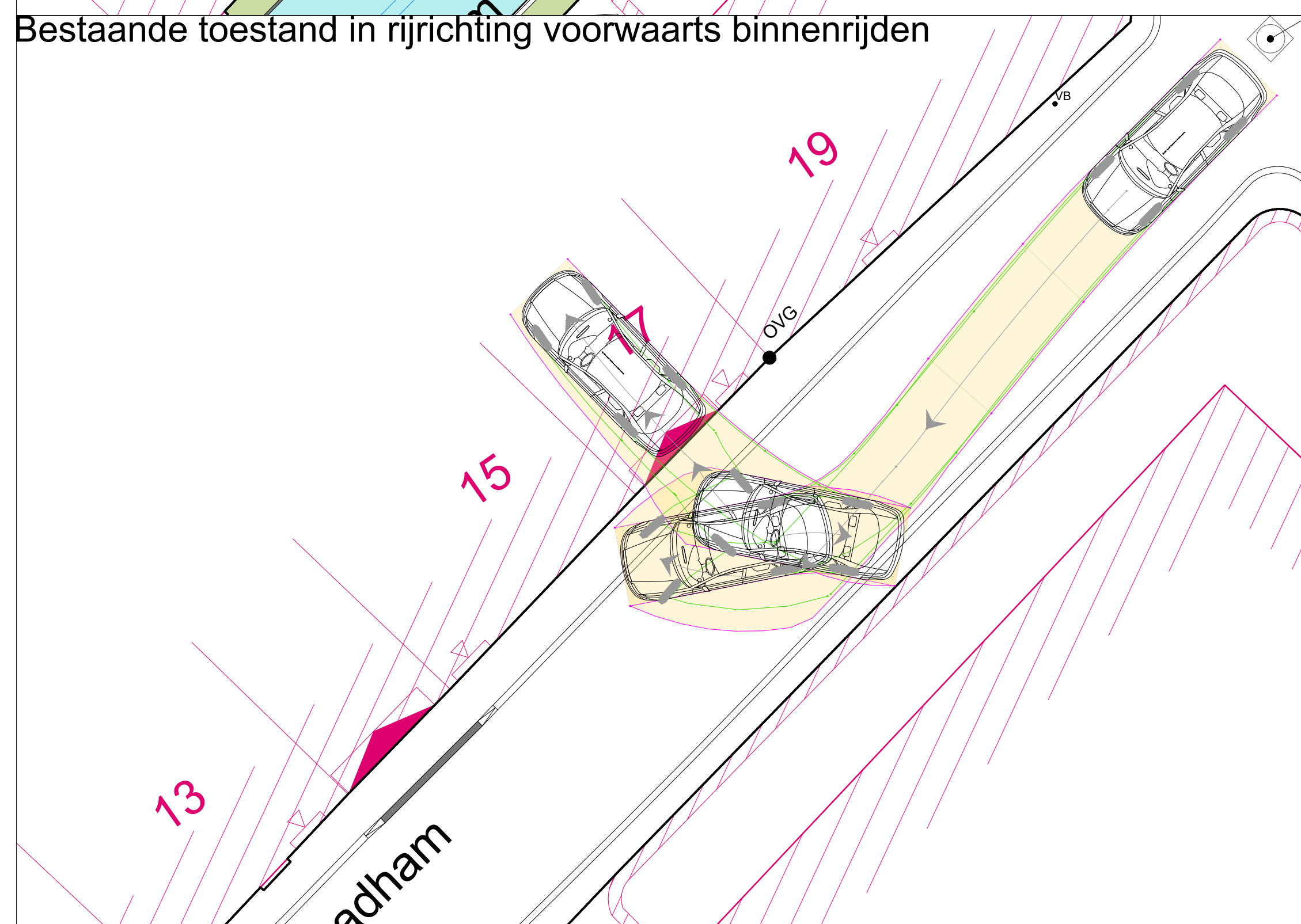

Bestaande toestand in rijrichting achterwaarts binnenrijden

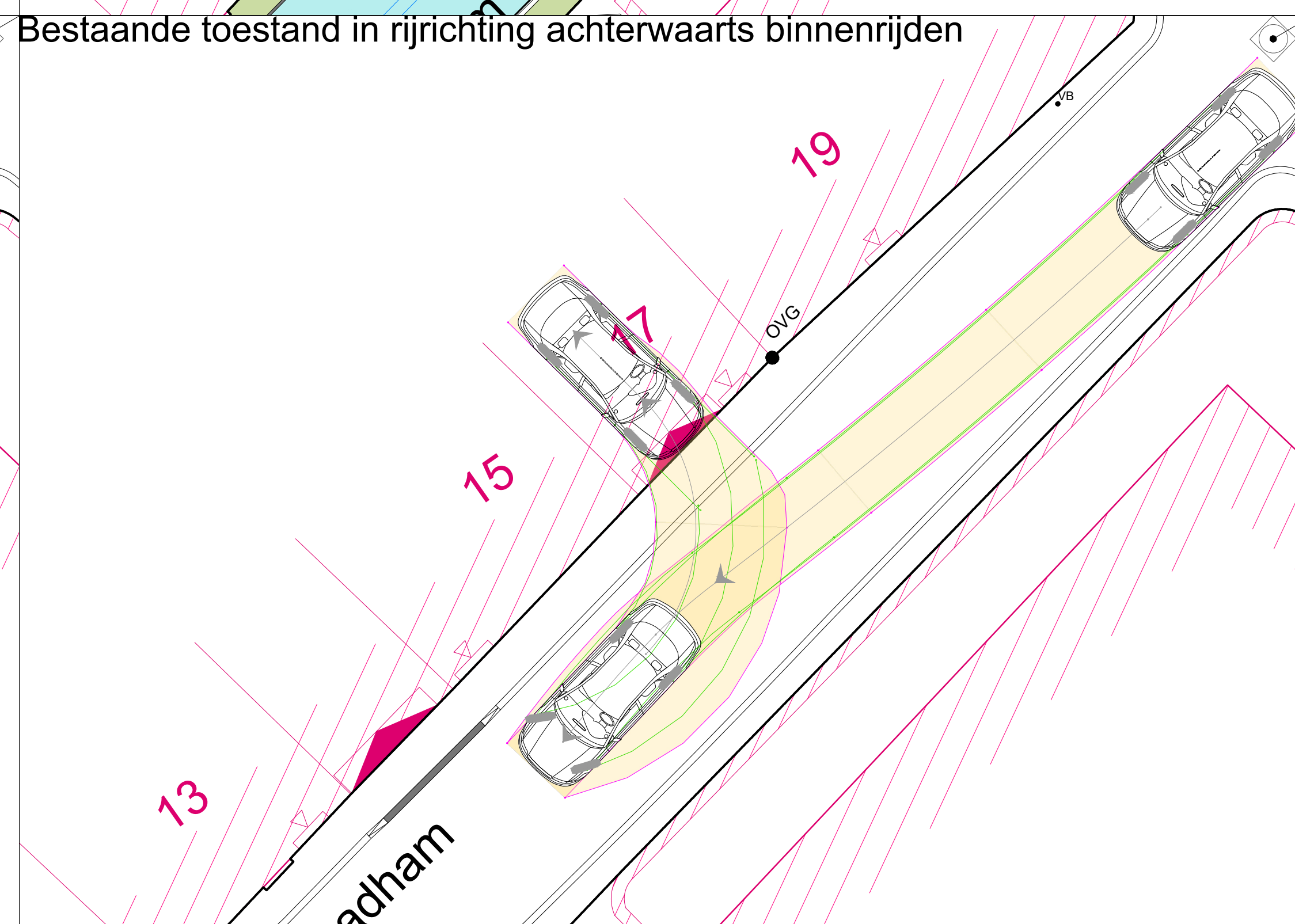

Bestaande toestand in tegenrichting voorwaarts binnenrijden

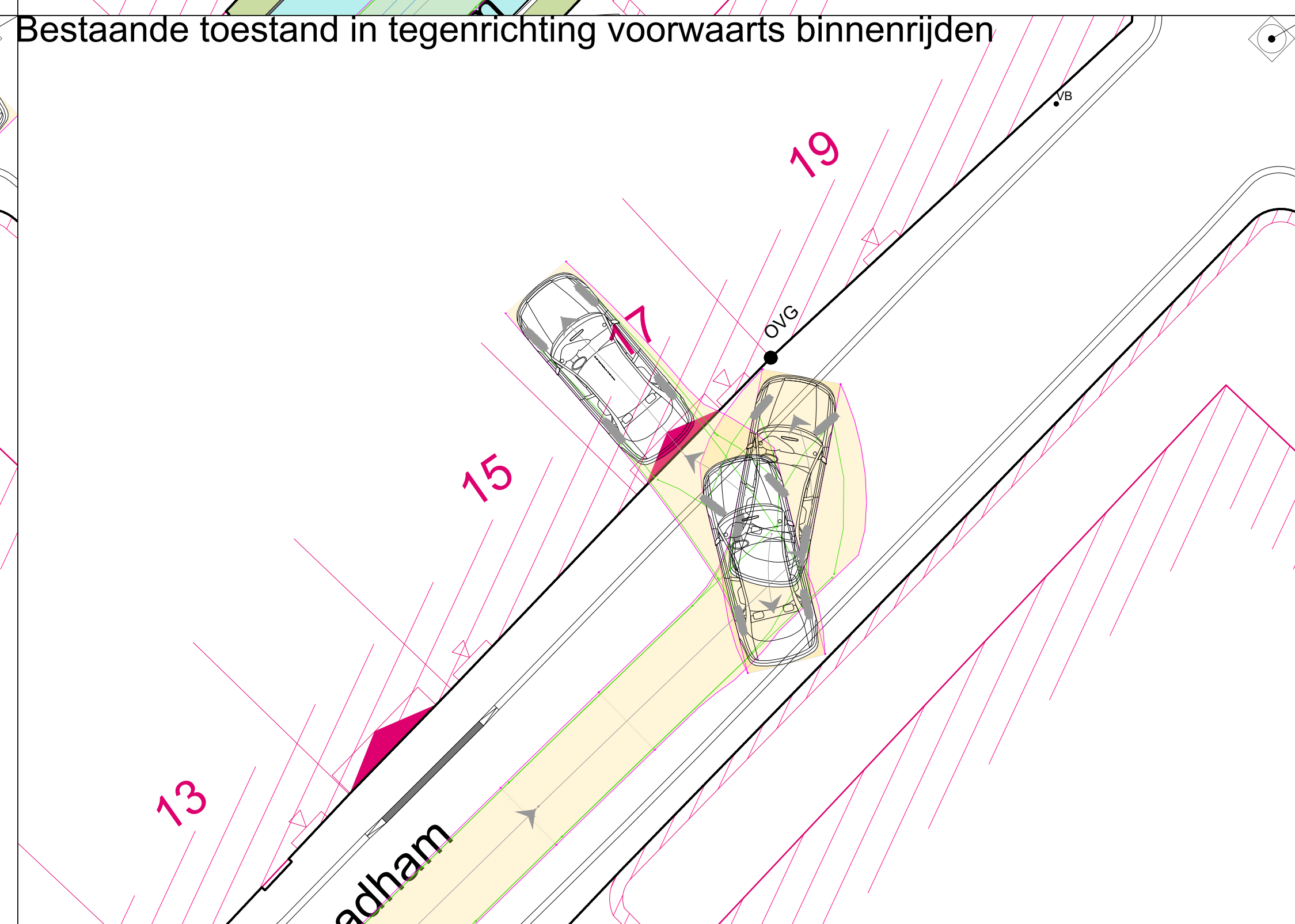

Bestaande toestand in tegenrichting achterwaarts binnenrijden

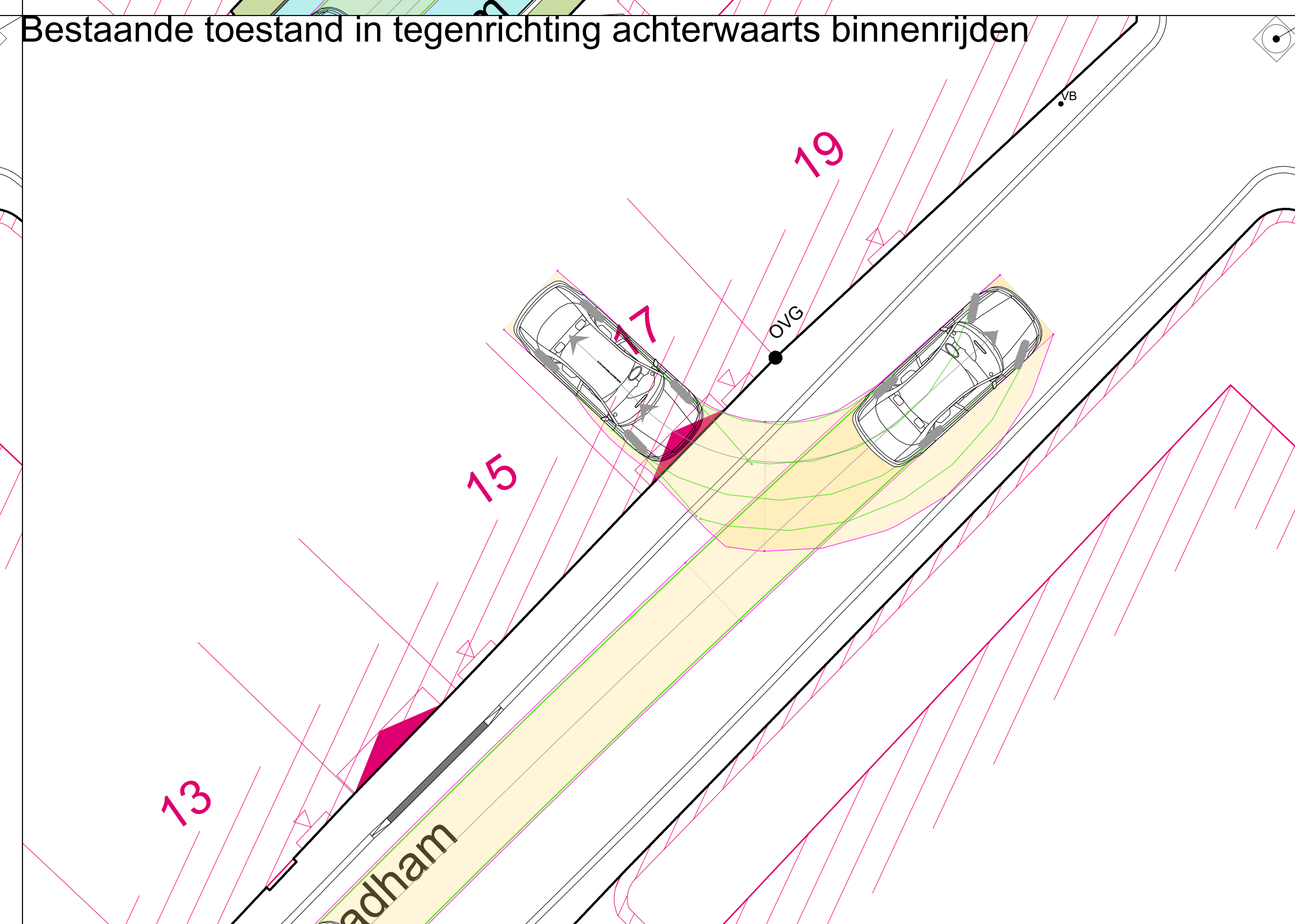



BARRESTRAAT - RIDDERSTRAAT SIMULATIES IVAGO

TR = TEGENRICHTING
RR = RIJRICHTING

SCHAAL:

In samenwerking met:



INDEX	DATUM	TEKENAAR	OMSCHRIJVING
A			

PDF by Vanreterghem Angelo on 10.02.2021 12:26; Papersize (HxB): 297mm x 840mm

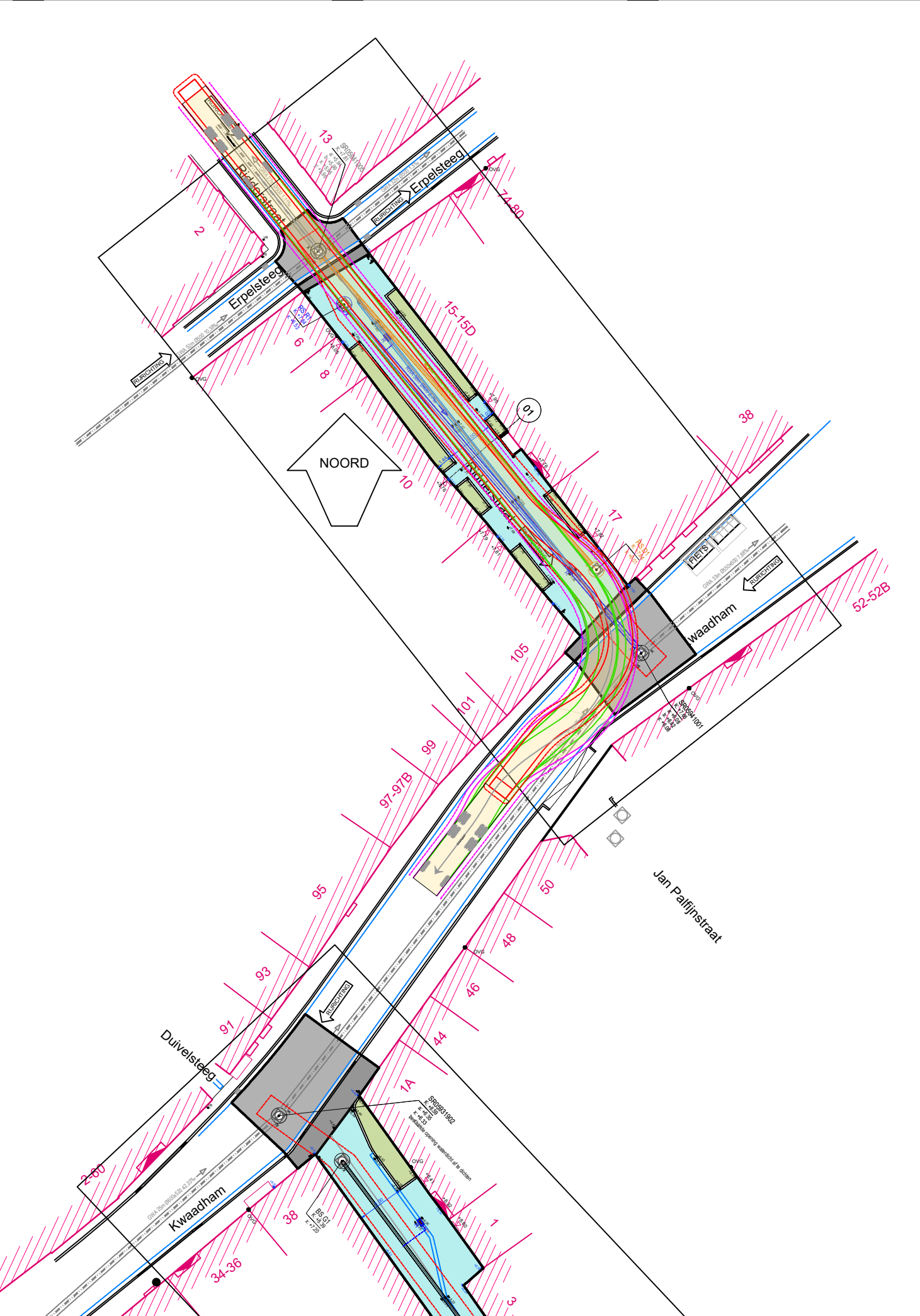

PDF by Vanrenterghem Angelo on 10.02.2021 12:25; Paper size (HxB): 297mm x 1050mm

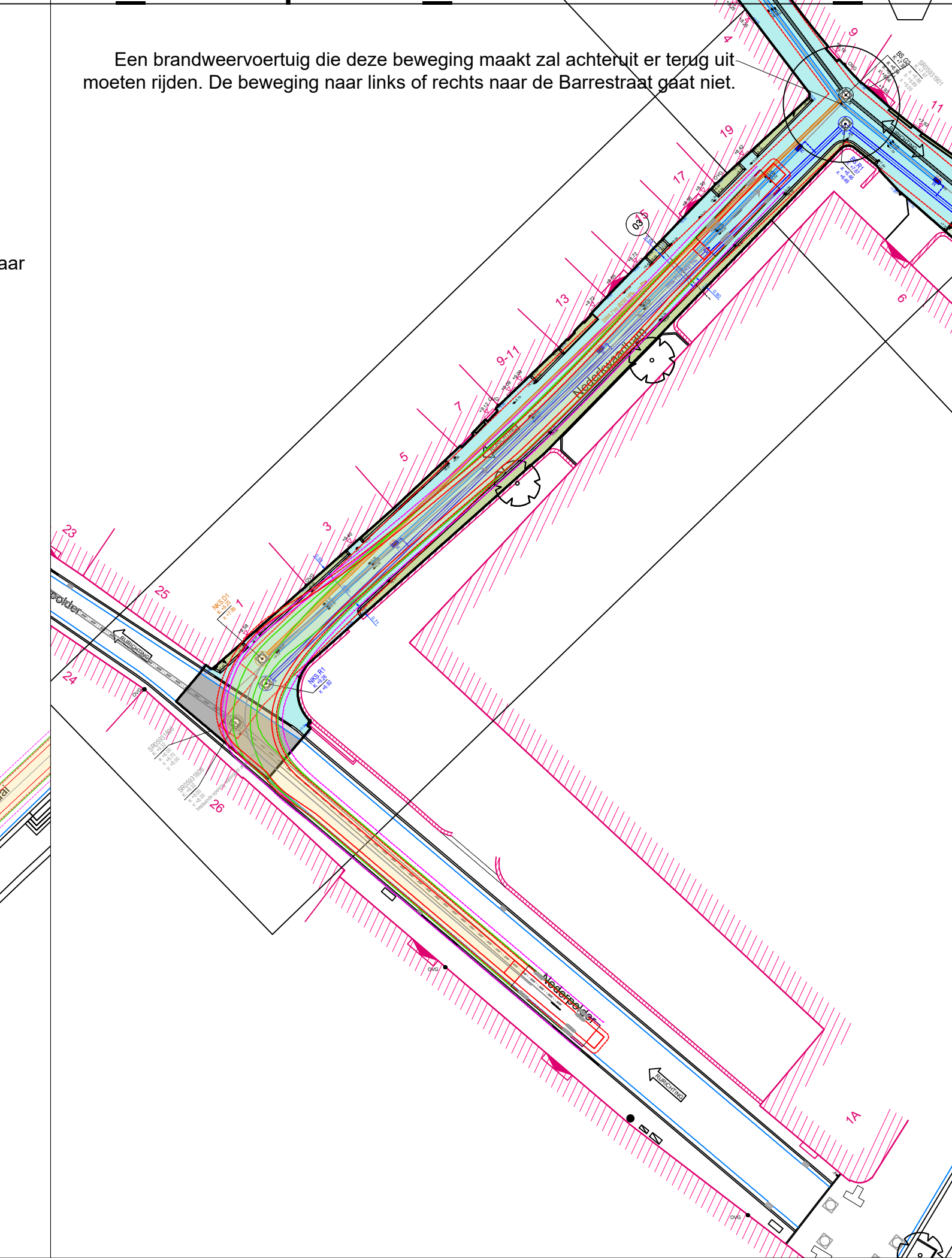
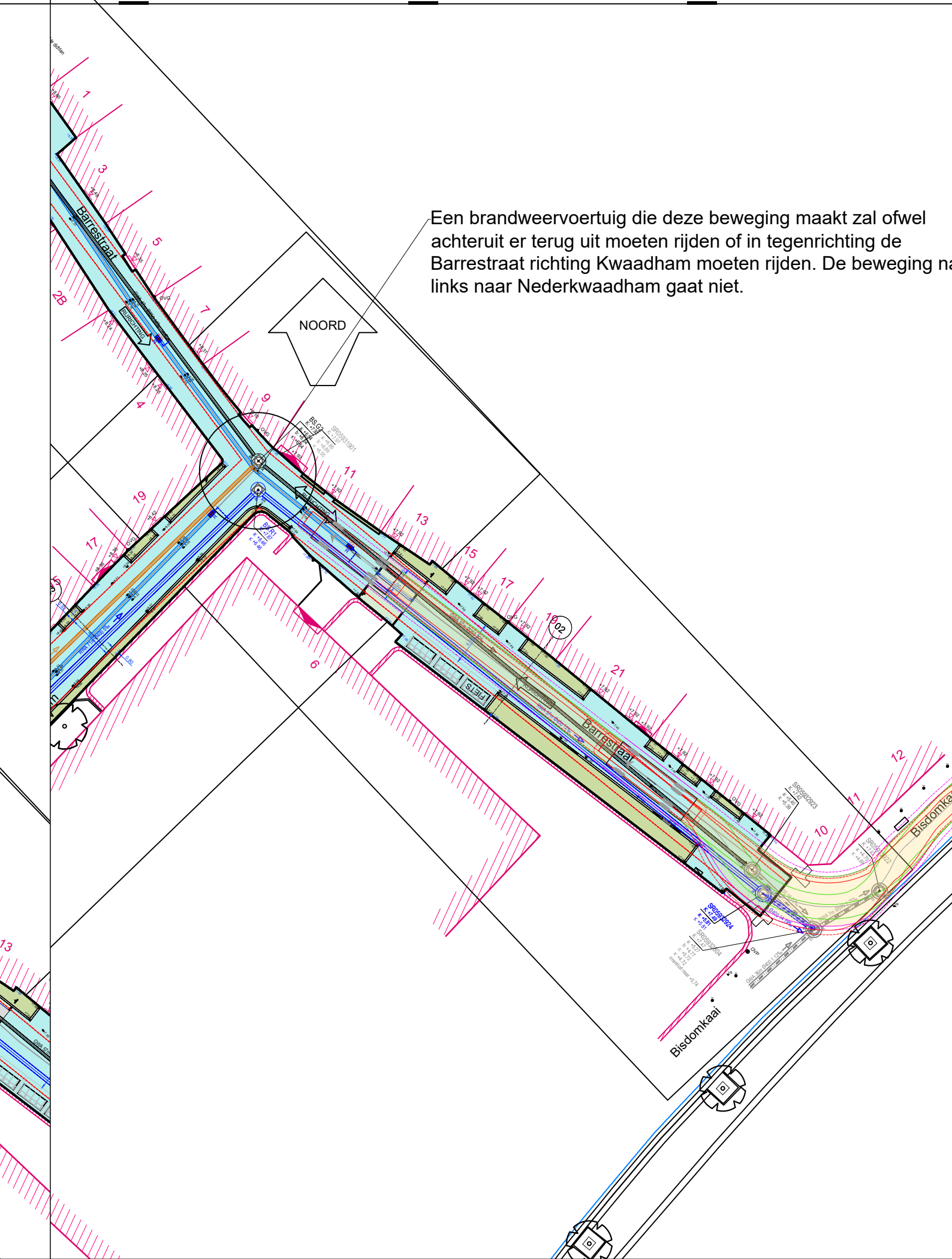
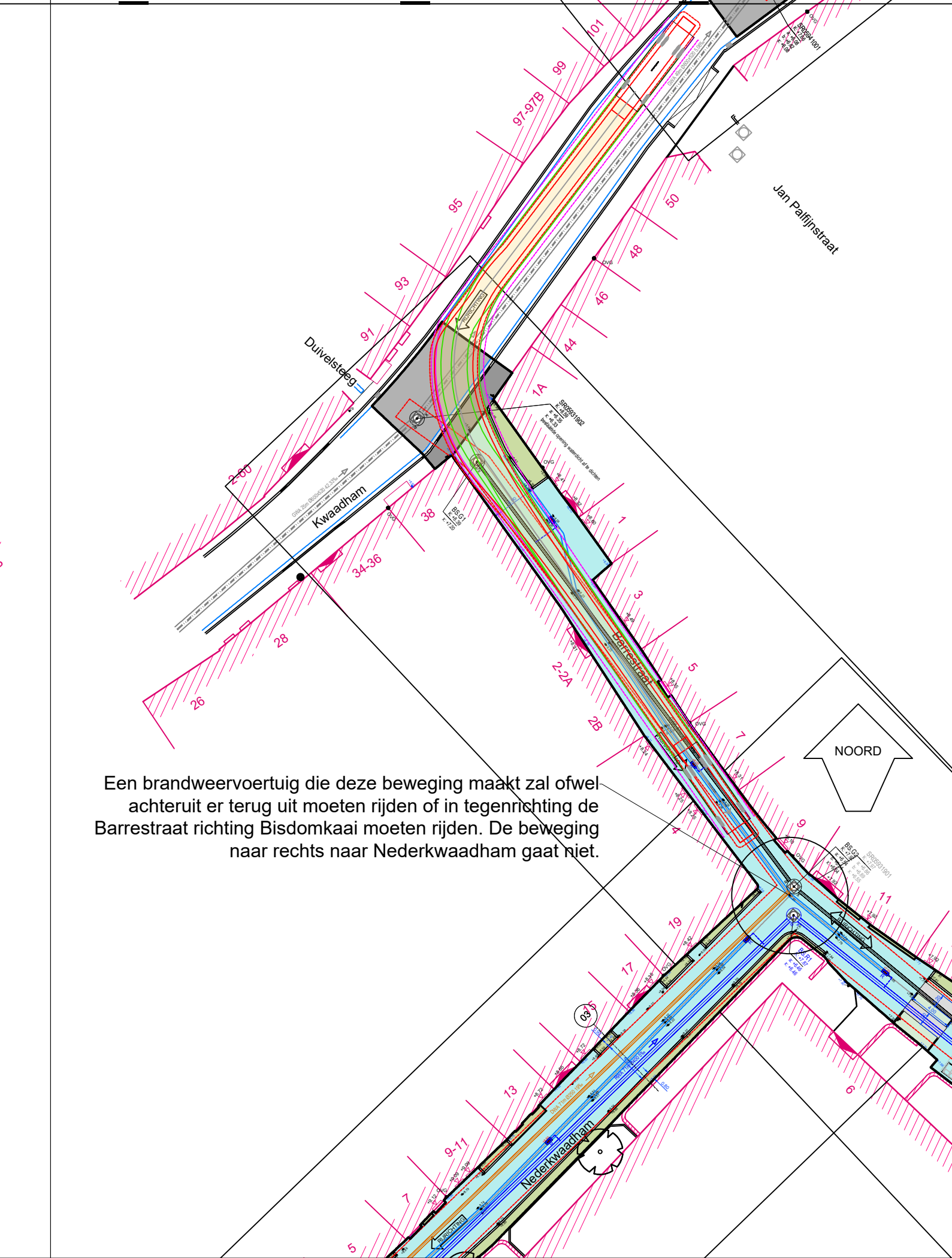
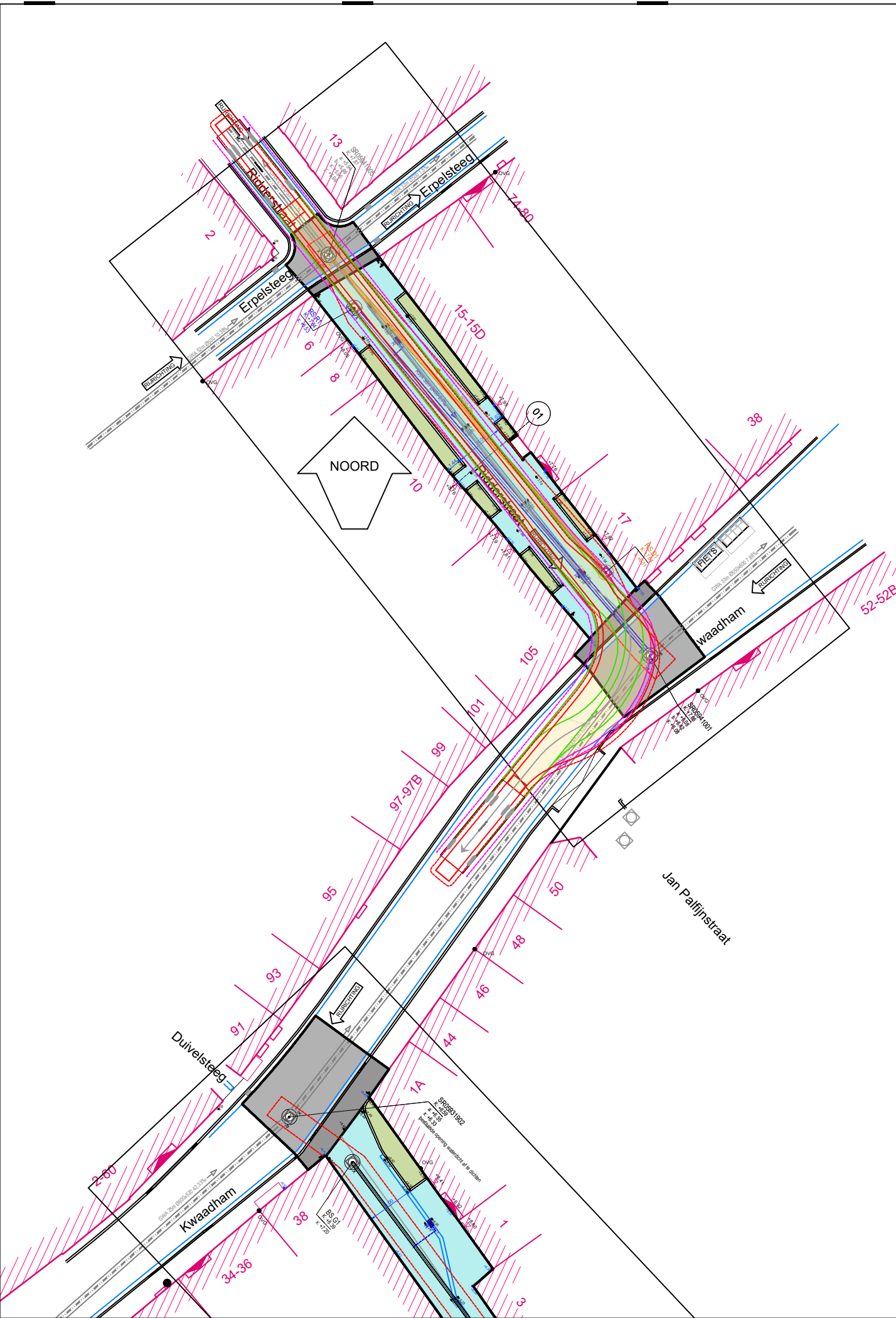

Een brandweervoertuig die deze beweging maakt zal ofwel achteruit er terug uit moeten rijden of in tegenrichting de Barrestraat richting Bisdomkaai moeten rijden. De beweging naar rechts naar Nederkwaadham gaat niet.

Een brandweervoertuig die deze beweging maakt zal ofwel achteruit er terug uit moeten rijden of in tegenrichting de Barrestraat richting Kwaadham moeten rijden. De beweging naar links naar Nederkwaadham gaat niet.

Een brandweervoertuig die deze beweging maakt zal achteruit er terug uit moeten rijden. De beweging naar links of rechts naar de Barrestraat gaat niet.



BARRESTRAAT - RIDDERSTRAAT
SIMULATIES BRANDWEER

TR = TEGENRICHTING
RR = RIJRICHTING

SCHAAL:

In samenwerking met:



INDEX	DATUM	TEKENAAR	OMSCHRIJVING
A			

Schaal 1/50

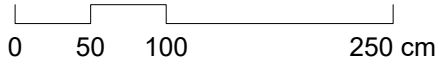

Referentiepeil: TAW

Eenheid: meters

RIDDERSTRAAT DWARSPROFIEL 01 BESTAANDE TOESTAND

15-15D

10

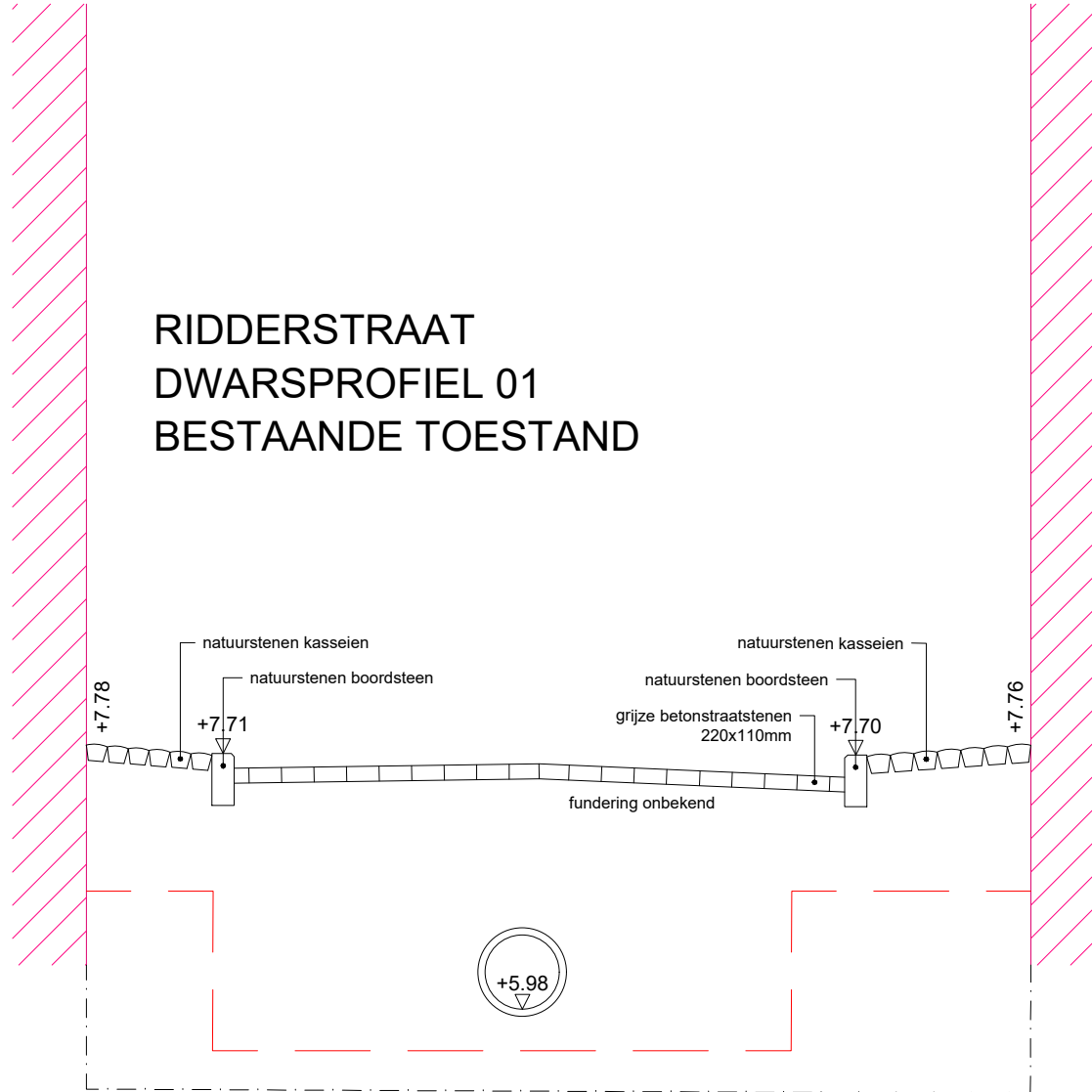

Schaal 1/50

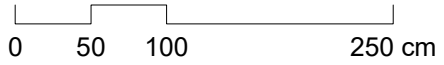

Referentiepeil: TAW

Eenheid: meters

BARRESTRAAT DWARSPROFIEL 02 BESTAANDE TOESTAND

19

6

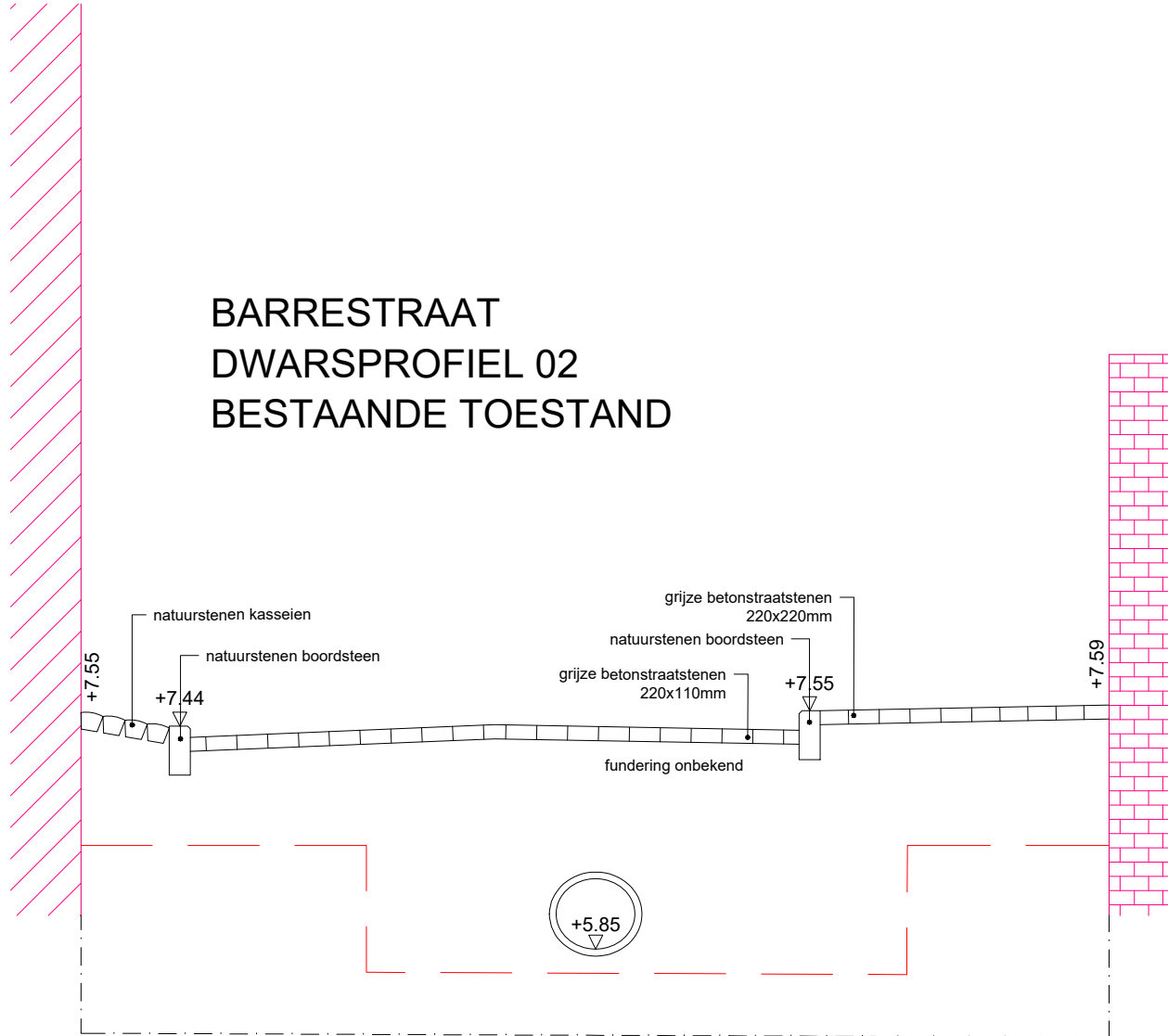

Schaal 1/50



Referentiepeil: TAW

Eenheid: meters

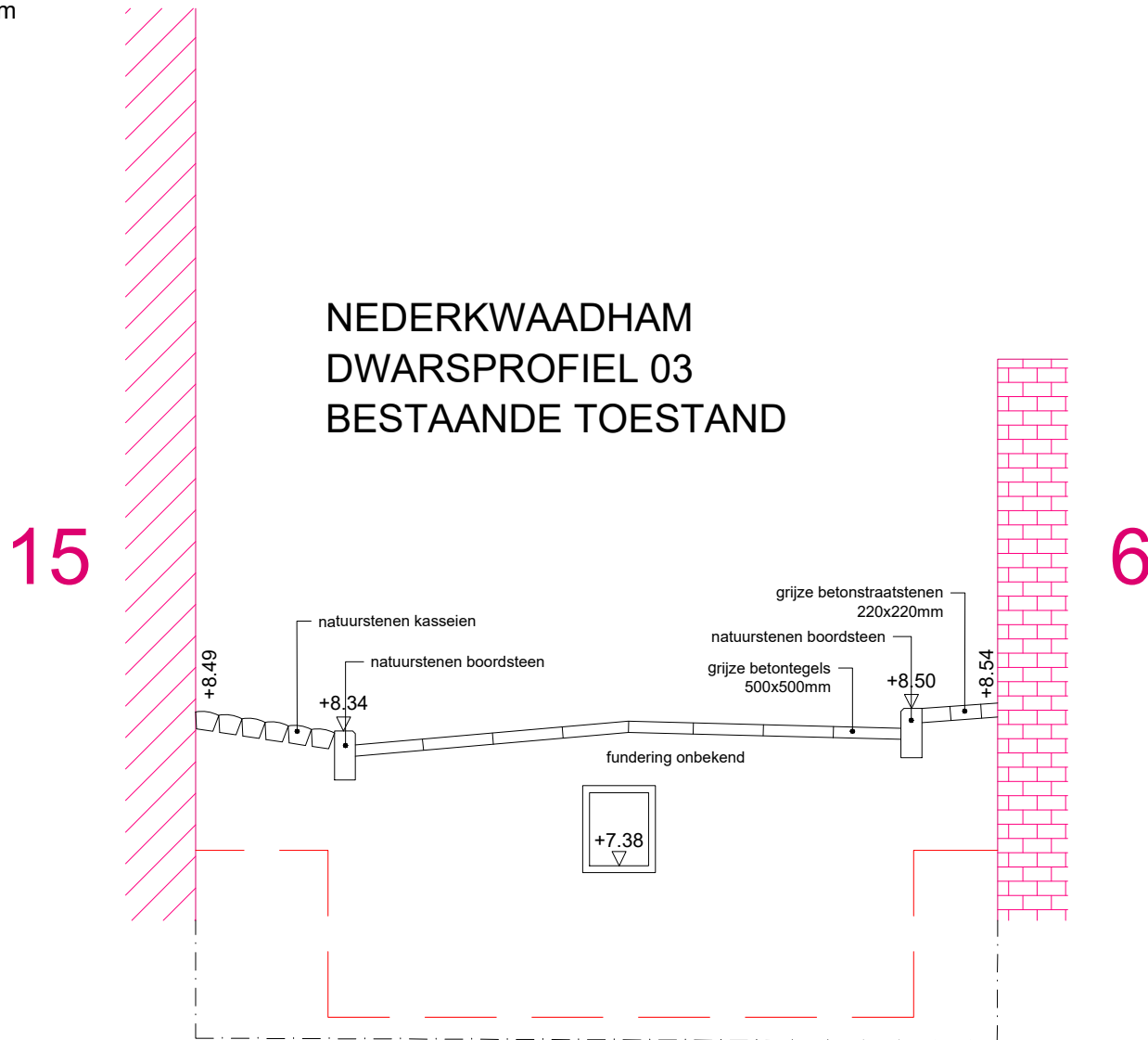

Schaal 1/50

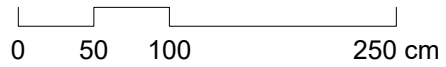

Referentiepeil: TAW
Eenheid: meters

RIDDERSTRAAT DWARSPROFIEL 01 NIEUWE TOESTAND

15-15D

10

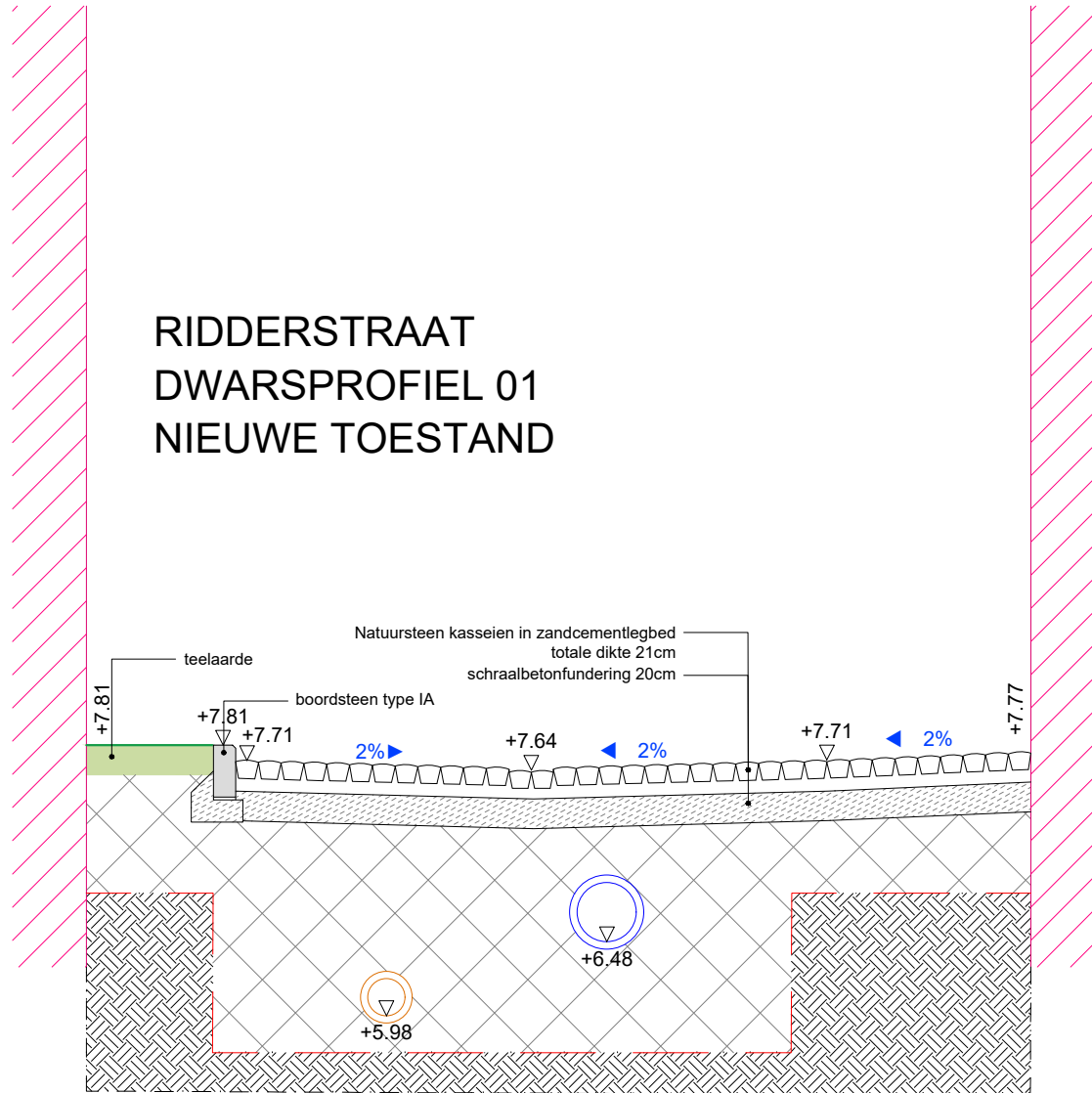

Schaal 1/50



Referentiepeil: TAW

Eenheid: meters

19

BARRESTRAAT DWARSPROFIEL 02 NIEUWE TOESTAND

6

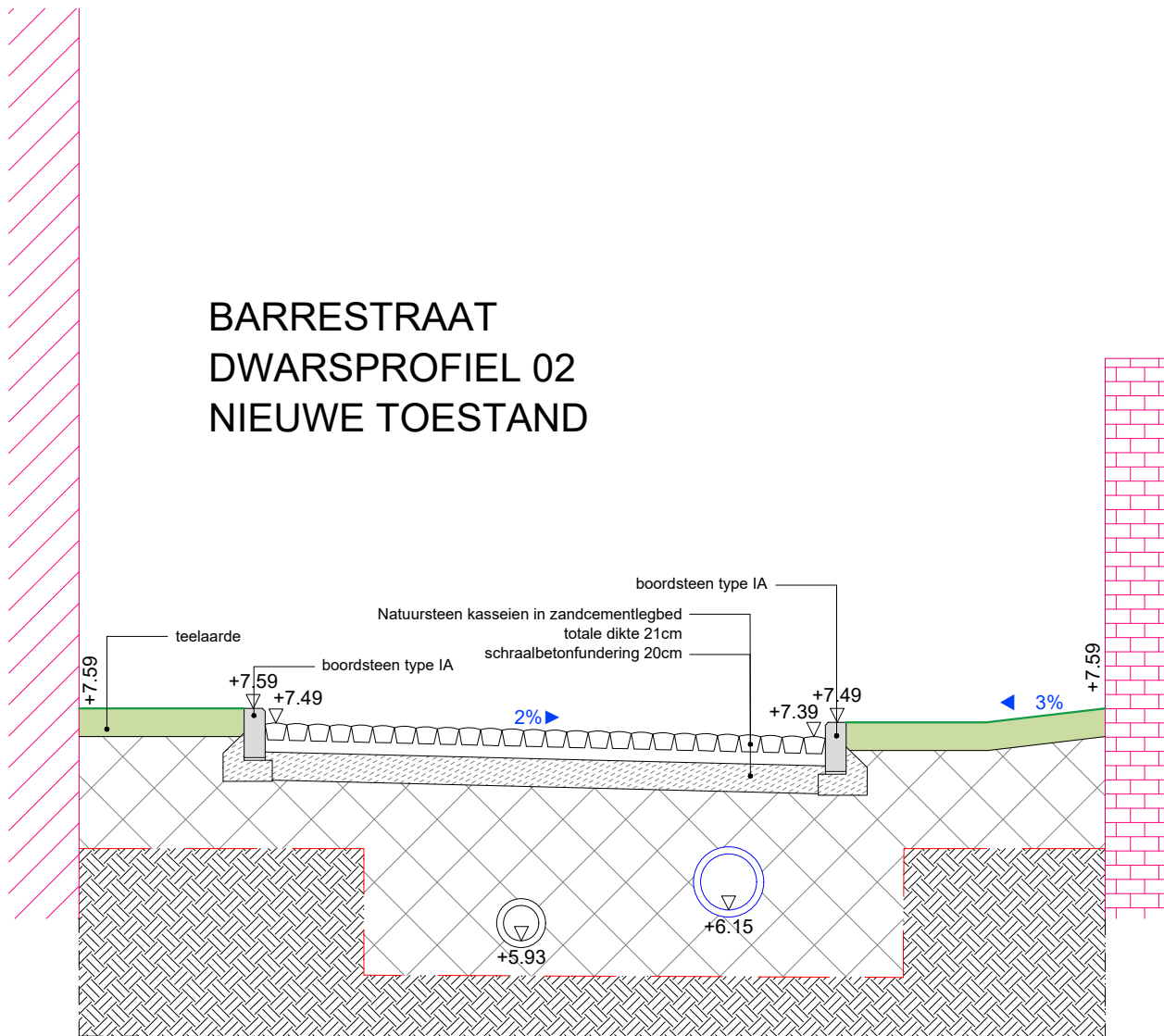

Schaal 1/50

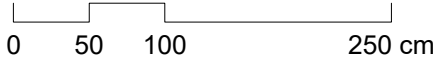

Referentiepeil: TAW

Eenheid: meters

